



Poznańskie Centrum Superkomputerowo-Sieciowe  
afiliowane przy Instytucie Chemii Bioorganicznej PAN

# The HPC-QC integration challenges for hybrid classical-quantum computing and initial use cases

Krzysztof Kurowski

*krzysztof.kurowski@man.poznan.pl*

Head of Quantum Technologies

Poznań Supercomputing and Networking Center

---

ISC'2026, QRUCH: Quantum Resources for Unified Computing Hub, 2nd Edition Workshop

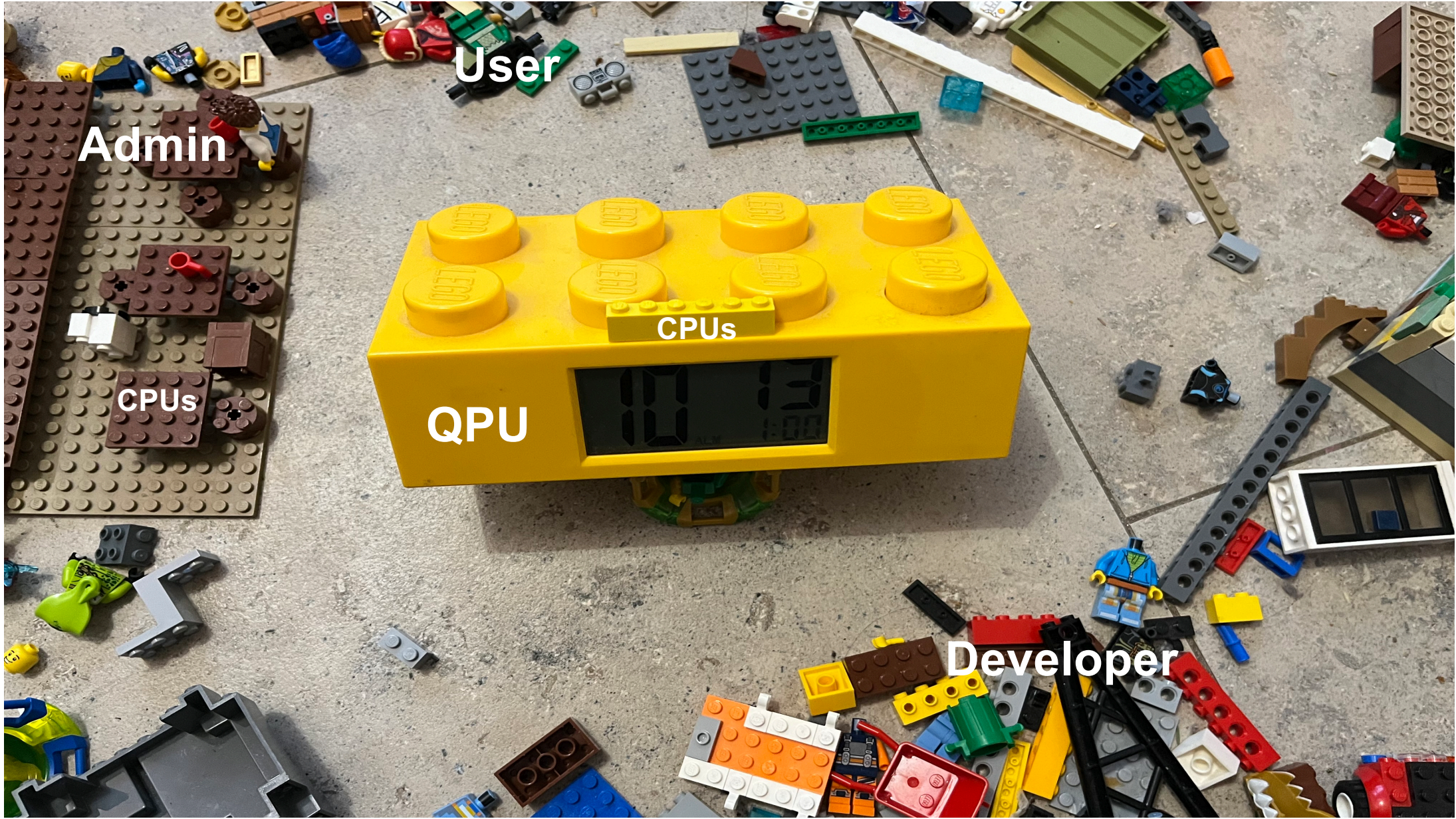

User

Admin

CPU's

CPU's

QPU

Developer

# HPC-QC integration



HPC



QC



# HPC-QC integration

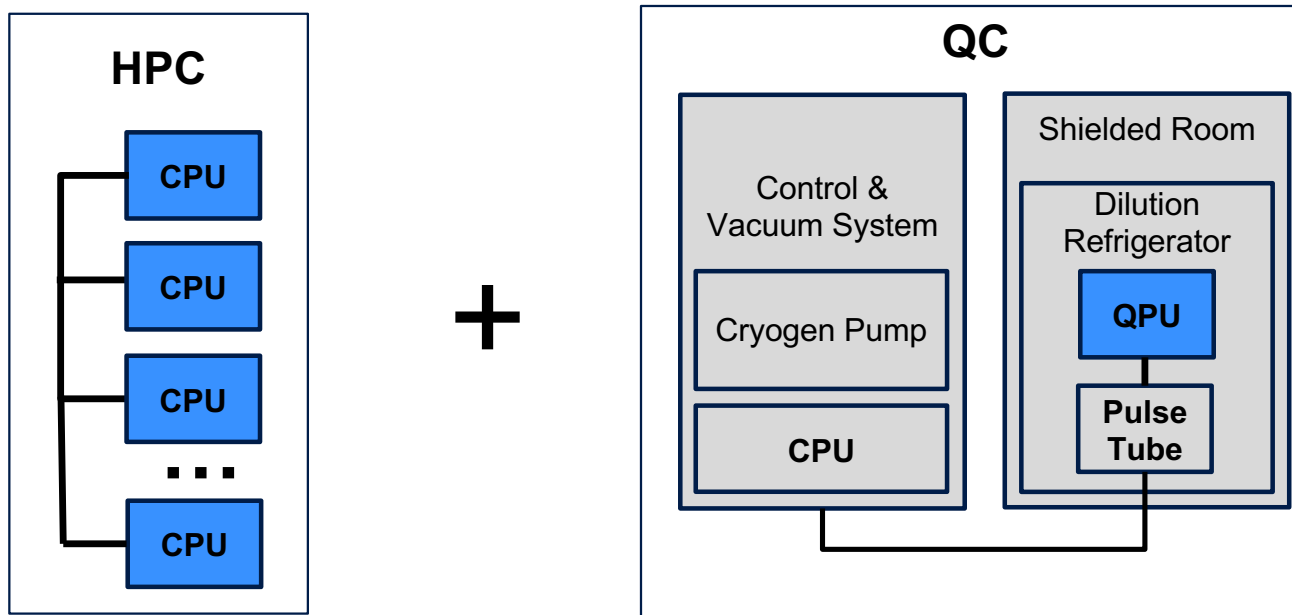

# HPC-QC challenges

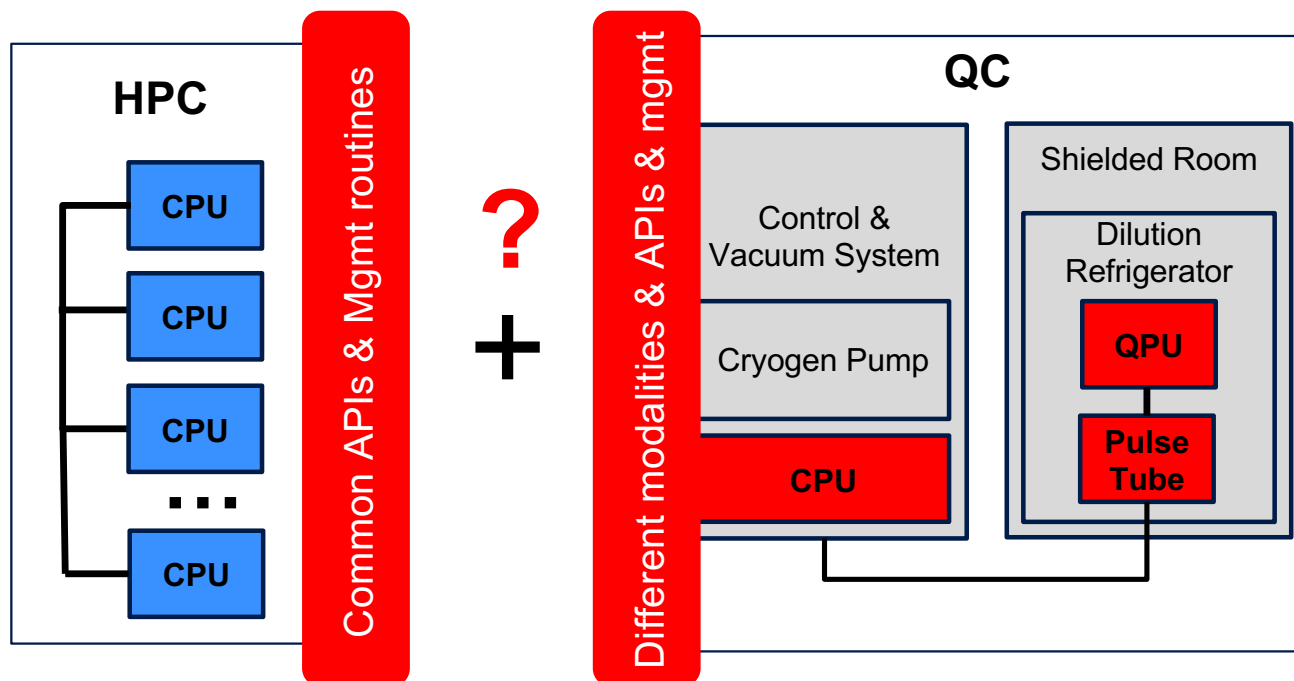

# HPC-QC scenario 1

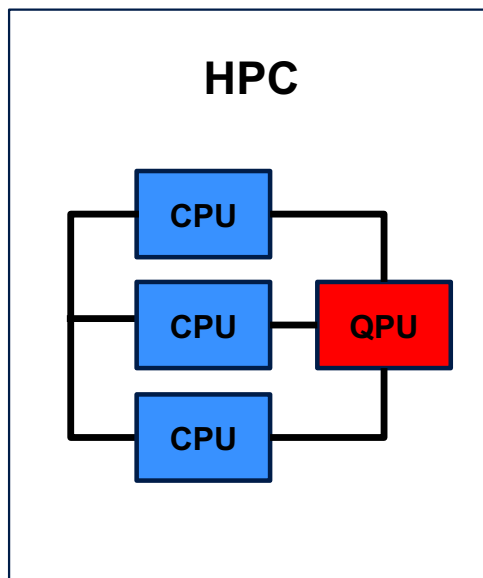

## HPC-QC at PCSS (EuroHPC infrastructure)





# THE EUROHPC QUANTUM COMPUTING INITIATIVE

## Seven different flavors of HPC-QC infrastructures

	<b>EuroQCS-France</b> GENCI/CEA	Photonic quantum computer			
	<b>Euro-Q-Exa</b> LRZ	Superconducting qubits			
	<b>EuroQCS-Italy</b> CINECA	Neutral atoms			
	<b>Lumi-Q</b> IT4I @ VSB	Superconducting qubits with a star-shaped topology			
	<b>EuroQCS-Poland</b> PSNC	Trapped ions			
	<b>EuroQCS-Spain</b> BSC-CNS	Quantum annealer			

# HPC-QC in EuroHPC

- **2 Quantum Simulators\* (100+ Qubits)**
  - Jülich: *Jewels – PASQAL QS (Germany)*
  - GENCI: *Joliot-Curie – PASQAL QS (France)*
- **6 Selected Hosting “Entities”**
  - Euro-Q-Exa, *superconducting Qubits (DE)*
  - LUMI-Q, *superconducting Qubits<sup>†</sup> (CZ)*
  - EuroQCS-Spain, *superconducting Qubits (ES)*
  - EuroQCS-Italy, *neutral atom Qubits\* (IT)*
  - **EuroQCS-Poland, *trapped ion Qubits (PL)***
  - EuroQCS-France, *photonic Qubits (FR)*
- **> 100.000.000 EUR of total investment**



 **EuroHPC QC  
Hosting Sites**

 **Quantum Sim.  
(HPCQS)**



\*) Fresnel analogue Quantum Simulator †) Star-shaped topology

# HPC-QC in EuroHPC

- 2 Quantum Simulators\* (100+ Qubits)
  - Jülich: *Jewels* – PASQAL QS (Germany)
  - GENCI: *Joliot-Curie* – PASQAL QS (France)
- 6 Selected Hosting “Entities”
  - Euro-Q-Exa, *superconducting Qubits* (DE)
  - LUMI-Q, *superconducting Qubits*<sup>†</sup> (CZ)
  - EuroQCS-Spain, *superconducting Qubits* (ES)
  - EuroQCS-Italy, *neutral atom Qubits*\* (IT)
  - EuroQCS-Poland, *trapped ion Qubits* (PL)
  - EuroQCS-France, *photonic Qubits* (FR)
- > 100.000.000 EUR of total investment

[www.piast-q.eu](http://www.piast-q.eu)

\*) Fresnel analogue Quantum Simulator †) Star-shaped topology

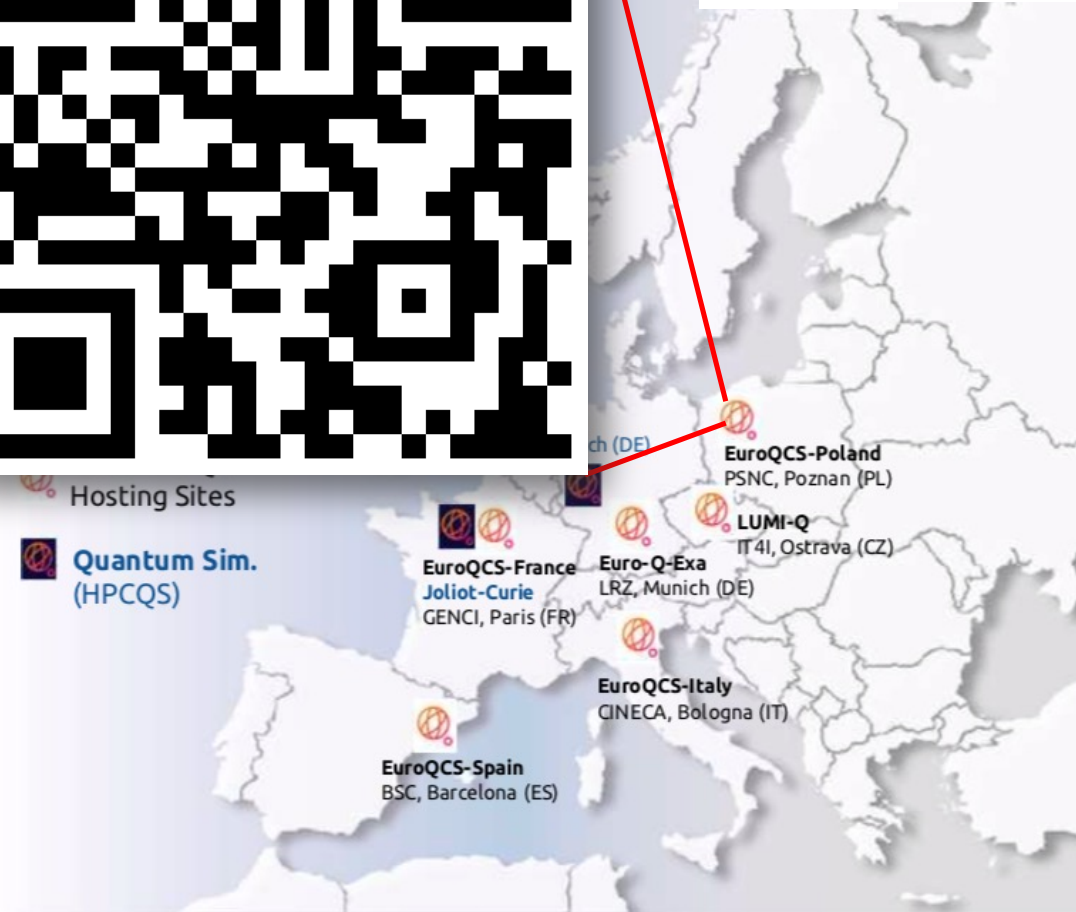
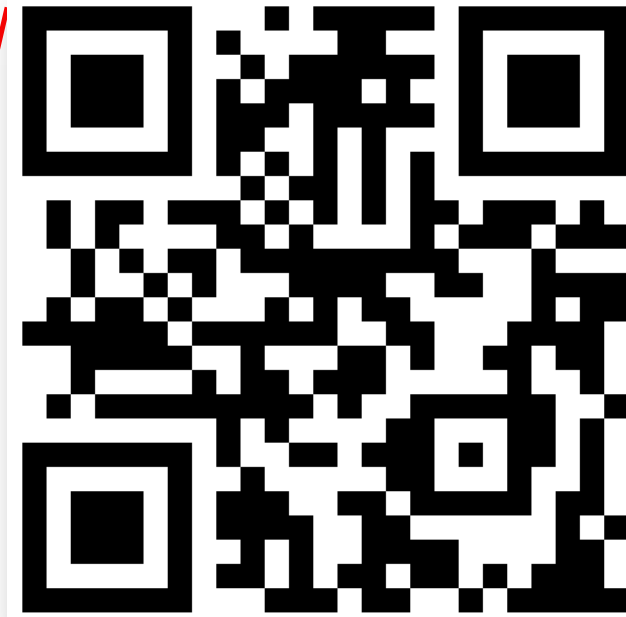

10 x QPU

# HPC-QC in EuroHPC

10 x HPC + 10 x QPU

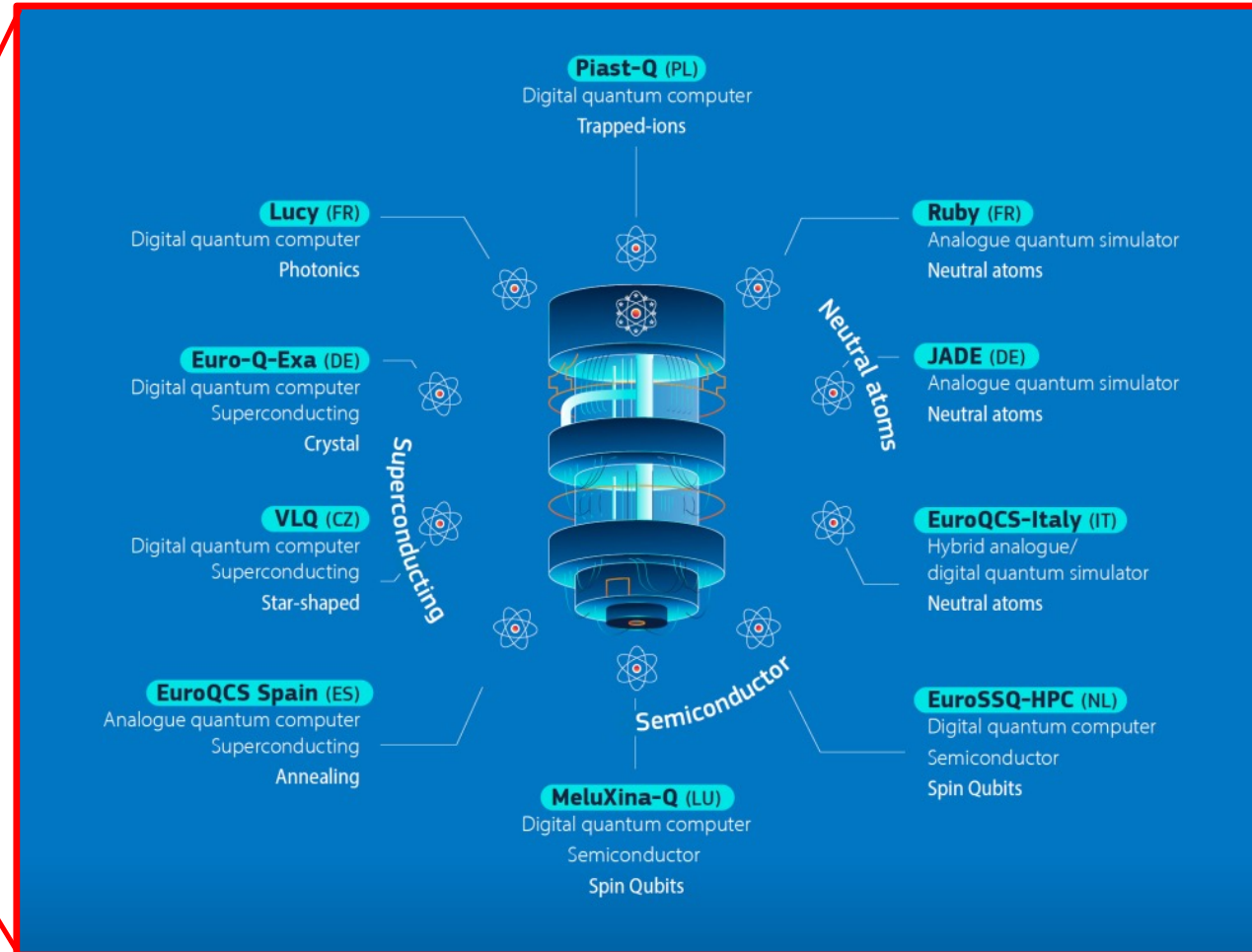
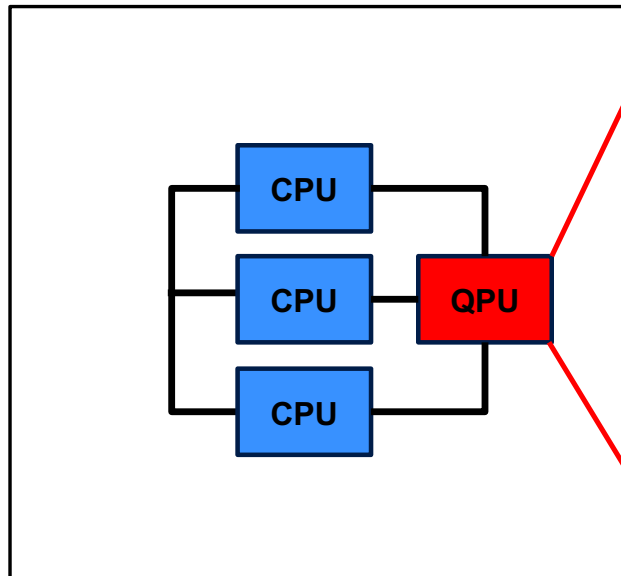

# HPC-QC in EuroHPC

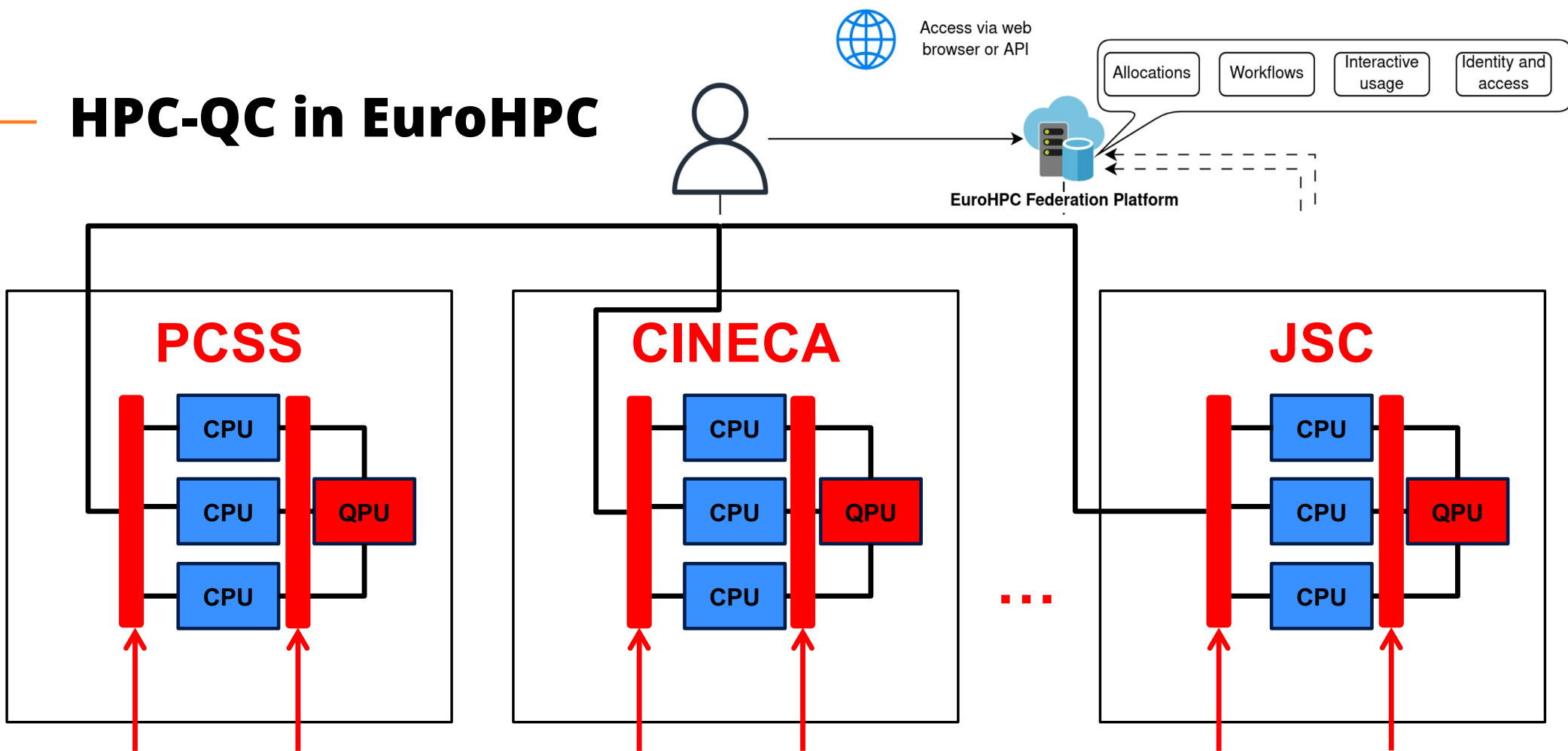

Different modalities, but ~~different~~ common APIs & ~~common~~ different mgmt

# HPC-QC at EuroHPC

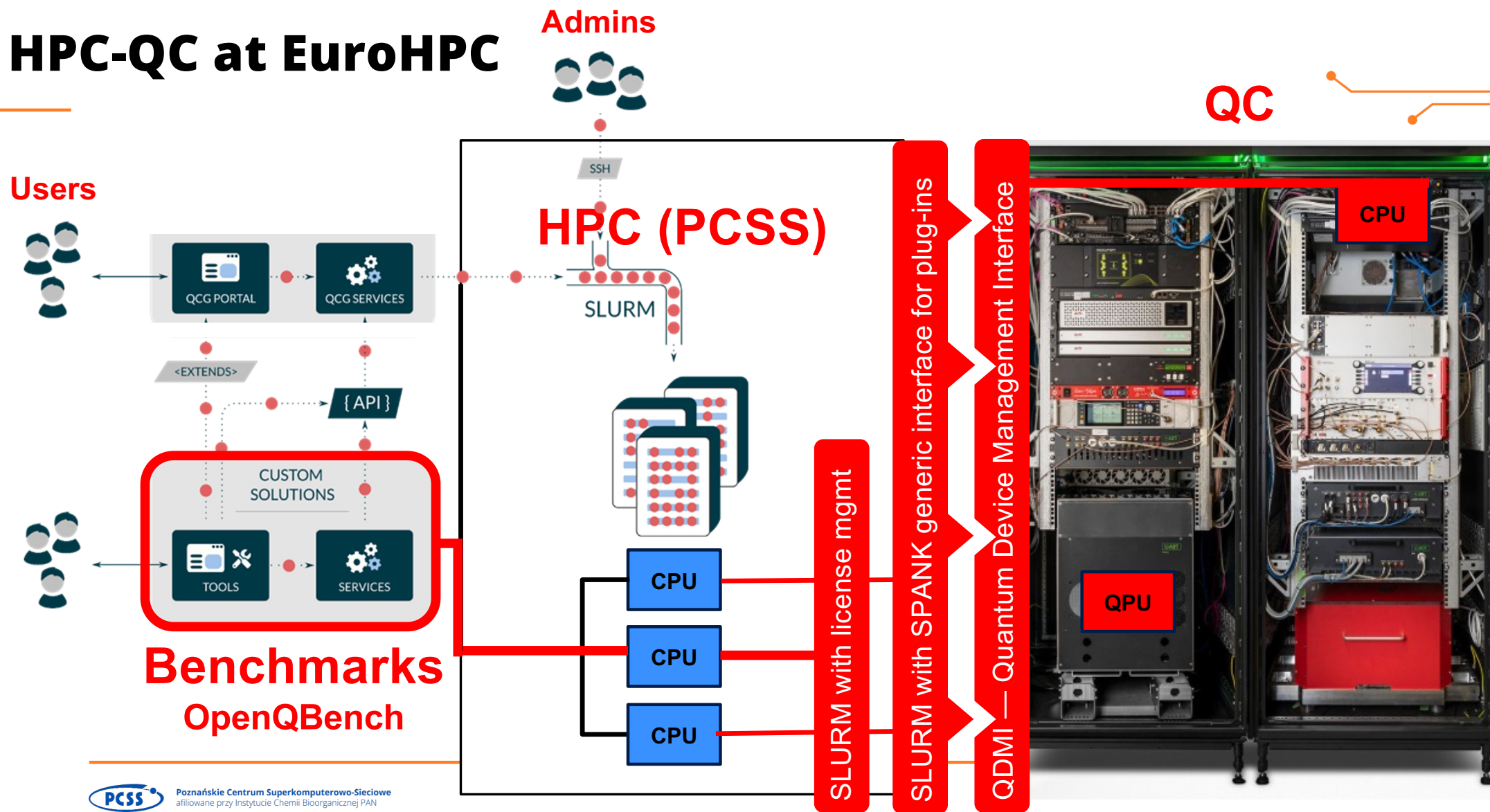

# Open QBench Application Benchmarking Suite

- 1 Entanglement in GHZ state
- 2 Toffoli gate
- 3 Grover's Algorithm
- 4 Quantum Fourier Transform
- 5 VQE for quantum chemistry
- 6 QAOA for combinatorial problems optimization
- 7 Quantum Support Vector Machine for classification
- 8 Quantum Walk

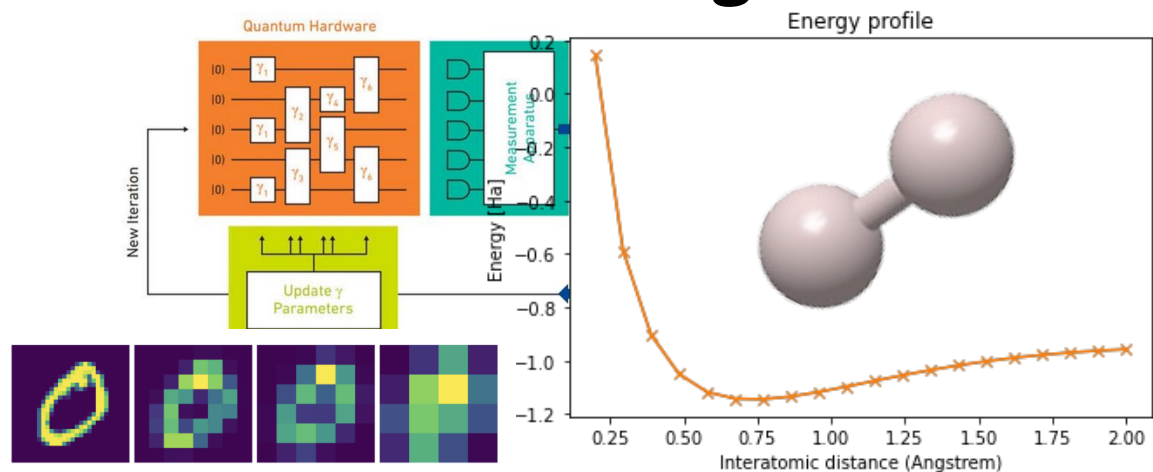

Home > Quantum Information Processing > Article

## Open QBench: A benchmarking framework for evaluating quantum computing platforms

Published: 09 March 2026  
Volume 25, article number 98 (2026) [Cite this article](#)

Access provided by Institute of Bioorganic Chemistry Polish Academy of Sciences

[Download PDF](#) [Save article](#)

[Quantum Information Processing](#)

[Aims and scope](#) [Submit manuscript](#)

<https://doi.org/10.1007/s11128-026-05115-2>

# QEC4QEA (Quantum Centre of Excellence for Quantum Enhanced Applications)



## WP2 Federated Platform and Access Development

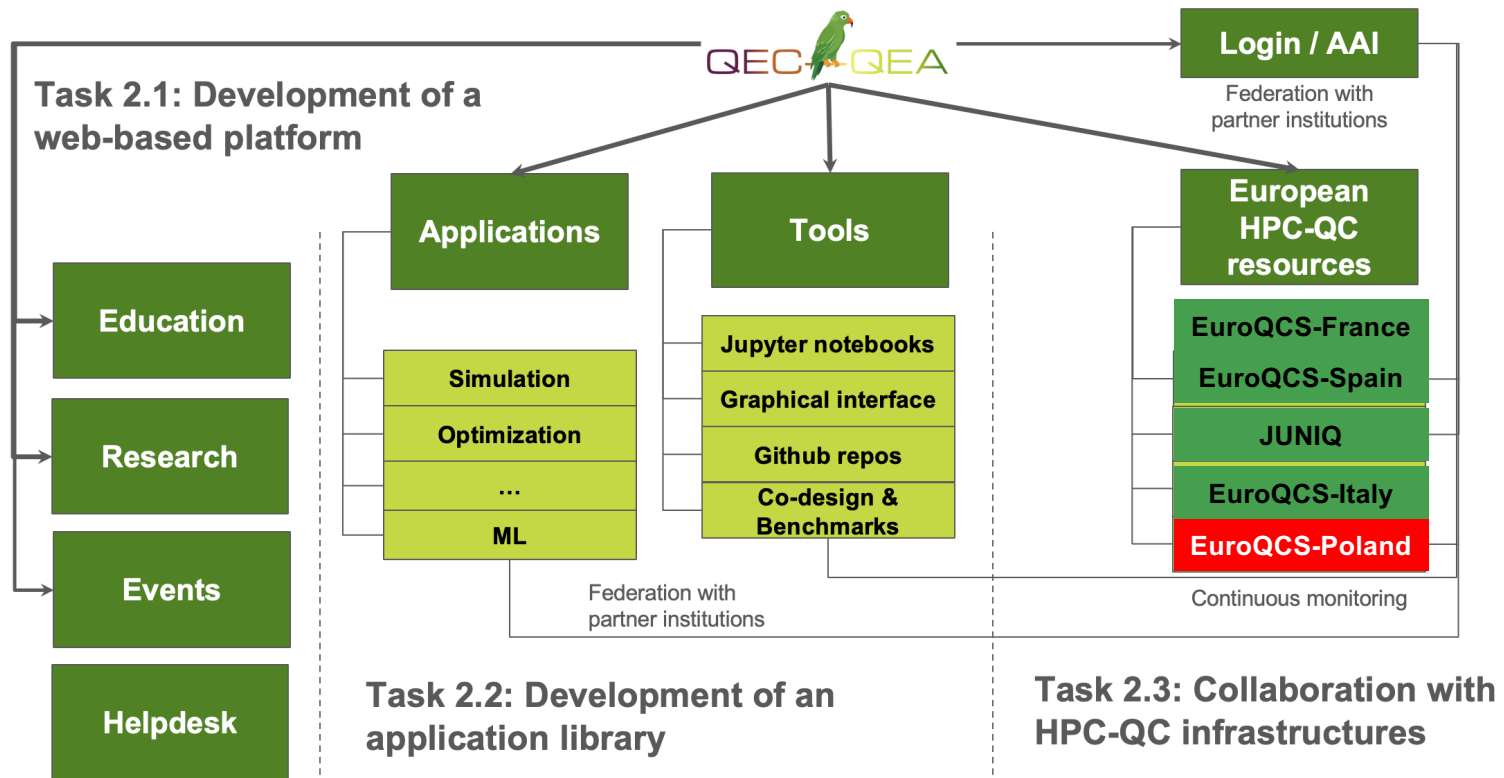

# New applications areas

- SI-A1: Quantum electrodynamics simulation (AMU, ICFO, CTP PAS)* →
- SI-A2: Stochastic models for risk analysis (CSIC)*
- SI-A3: Manufacturing simulation application (FZJ, KU)*
- OPT-A1: Quantum molecular unfolding and docking (CINECA, E4, PSNC)*
- OPT-A2: Graph Coloring Problem, Maximum Independent Set (LINKS, UniPD, RUD, ICFO)*
- OPT-A3: Quantum optimization for nonlinear finite-difference time-domain models (KU, BSC)*
- OPT-A4: Scheduling problems (UniPD, PSNC, RUD, FZJ, VU, ICFO)*
- OPT-A5: VQAs for optimizing the location of EV charging stations (VU, PSNC)*
- OPT-A6: Portfolio optimization and prediction of financial crashes (MULT, KU).*
- OPT-A7: Optimization for manufacturing (Multi-disk clutch) (MULT, KU)*
- OPT-A8: Routing problem and Satisfiability Problems in Maritime Logistics (FhG CML, KU)*
- OPT-A9: Planning and operation of power networks (FZJ, ICFO, BSC)*
- OPT-A10: Advanced ansatz for chemically accurate quantum algorithms (QUBIT, CTP PAS, BSC)*
- ML-A1: Quantum-optical phenomena for kernel based QML (AMU, ICFO, CTP PAS)*
- ML-A2: Graph classification (LINKS, KU)*
- ML-A3: Generative modeling for stochastic time series (CSIC)*
- ML-A4: Satellite image analysis (FZJ)*
- OA-A1: Integer factorization (RUD, UniPD, E4, FZJ) and Post-quantum cryptography - PQC algorithms (ICFO, AMU)*
- OA-A2: Solving partial differential equations - PDE (UniPD, CEA, MULT, CSIC, BSC)*



SI-A1 Quantum  
Electrodynamics Simulation

QEC

Adam Miranowicz

## HPC-QC scenario 2

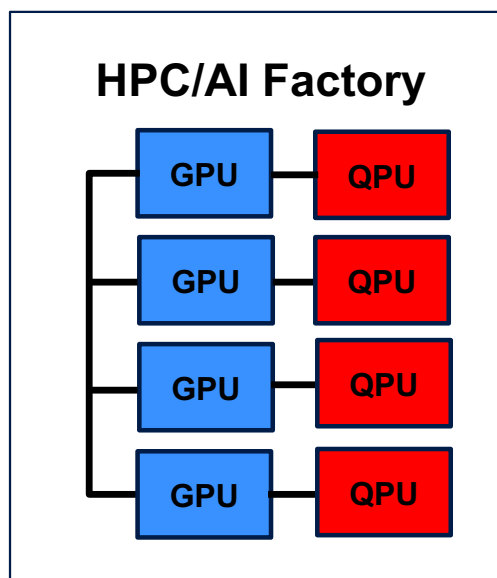

## HPC-QC at PCSS (National EuroHPC PL infrastructure)



# HPC-QC at PCSS

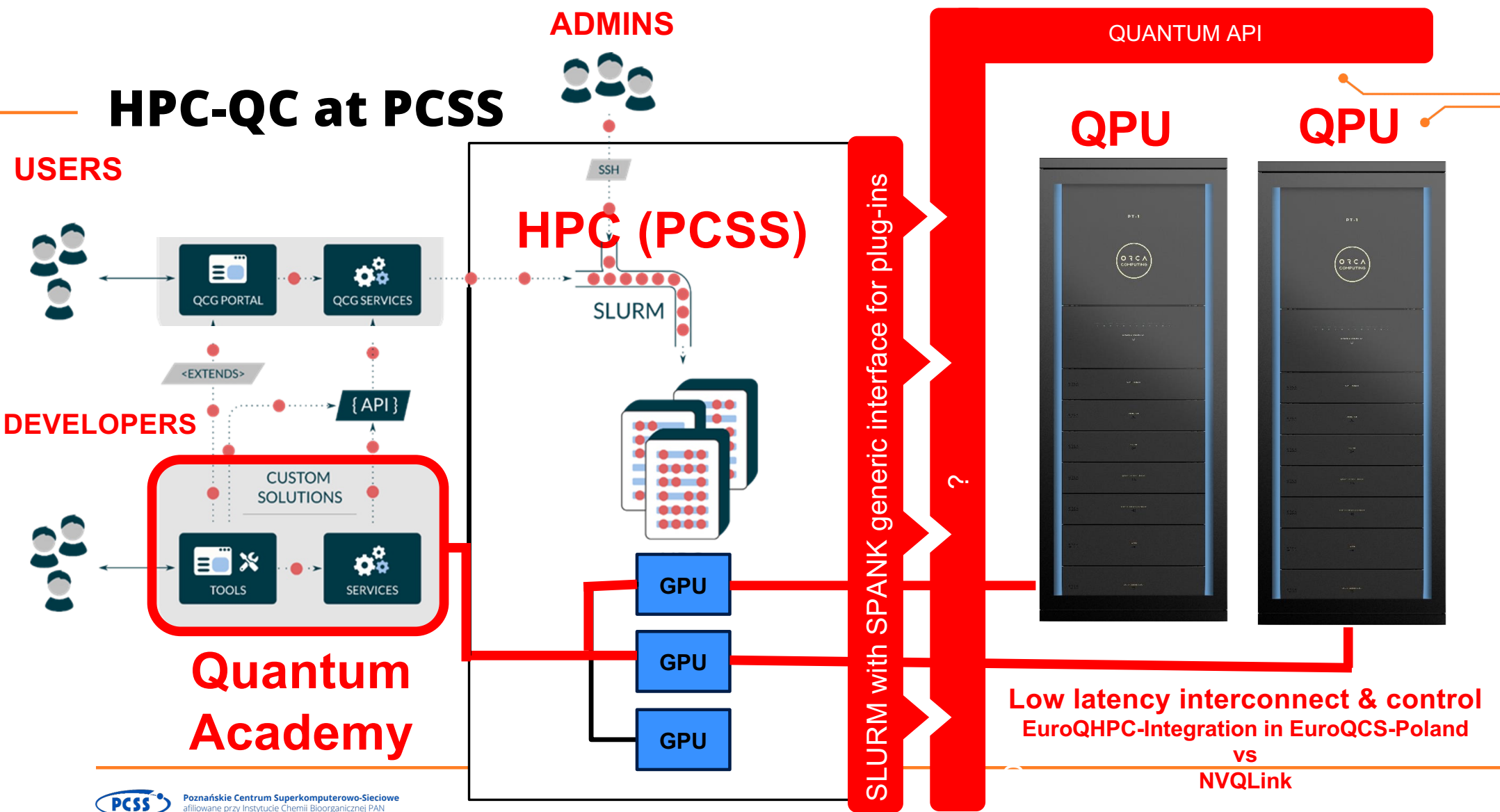

# Is there any other interface?

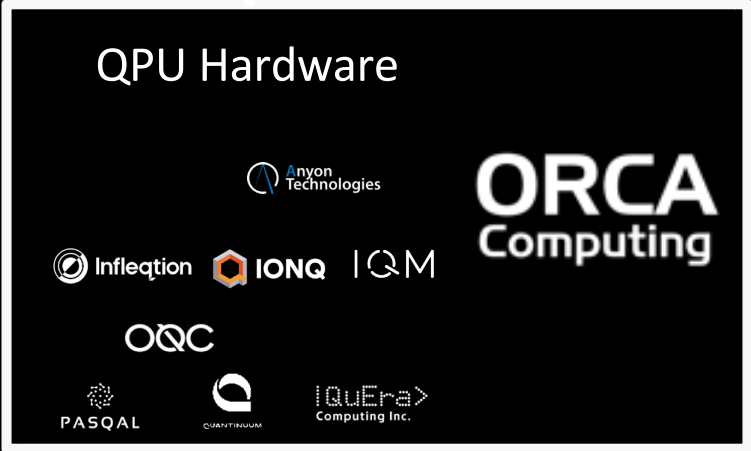
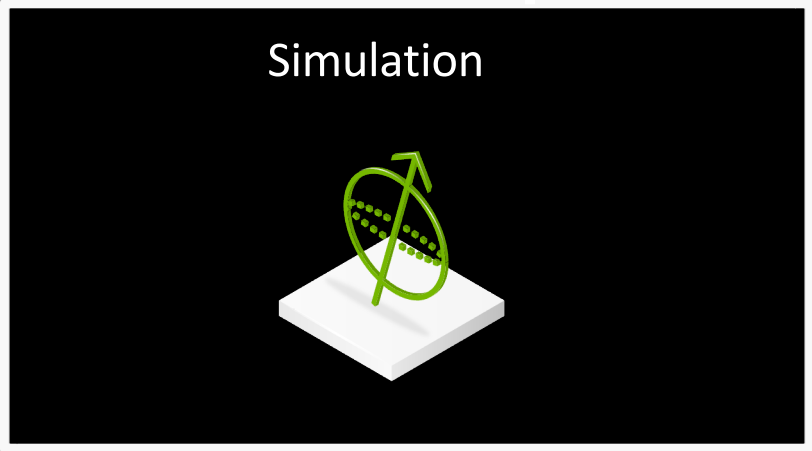
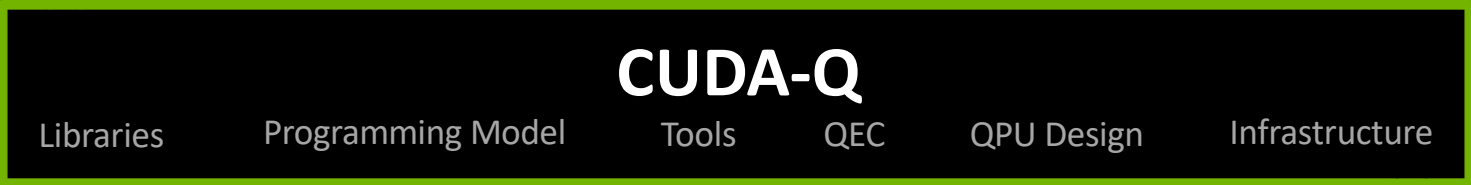

# Admins (Multi-QPU/GPU setup)

Setup consists of:

- two ORCA PT-1 QPUs
- multi-threaded CPU server
- virtualized GPU

In terms of software stack

- SLURM
- CUDA-Q
- ptseries

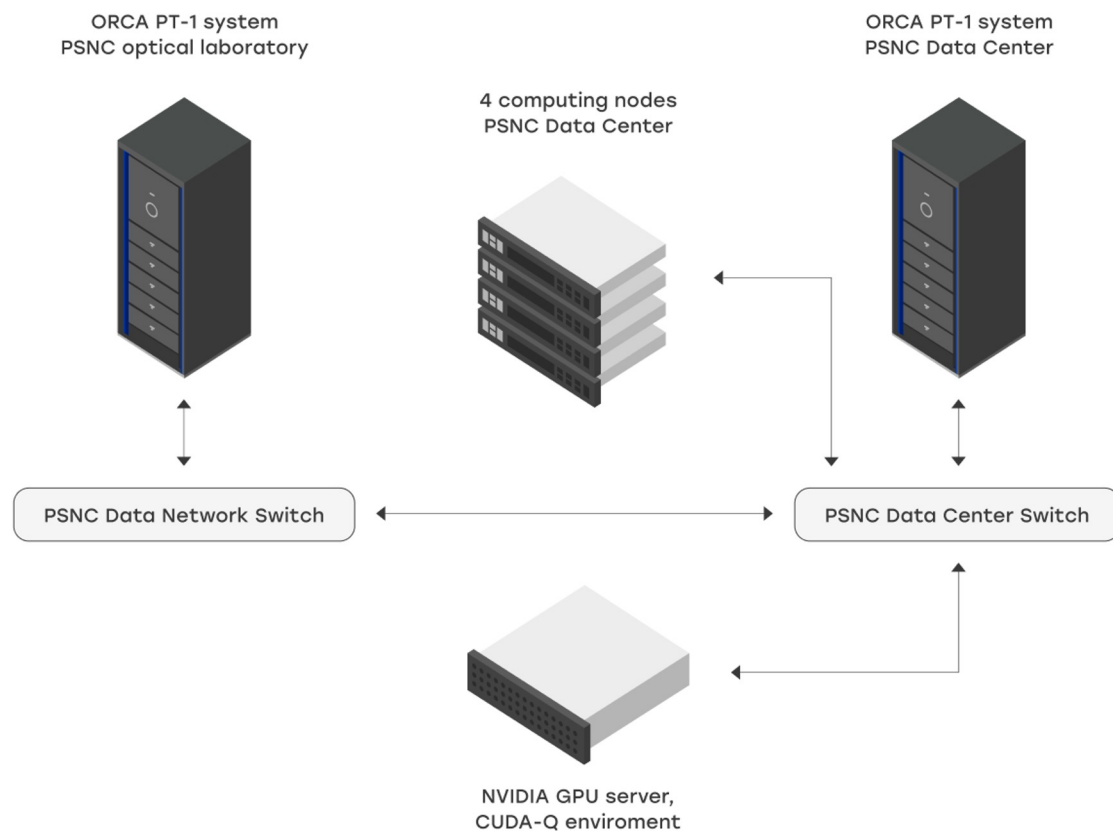

# Developers

SLURM:

- allocation with `-L` switch
- possibility to allocate  $>1$  QPU

CUDA-Q sets target to ORCA QPU  
for asynchronous execution of QML jobs

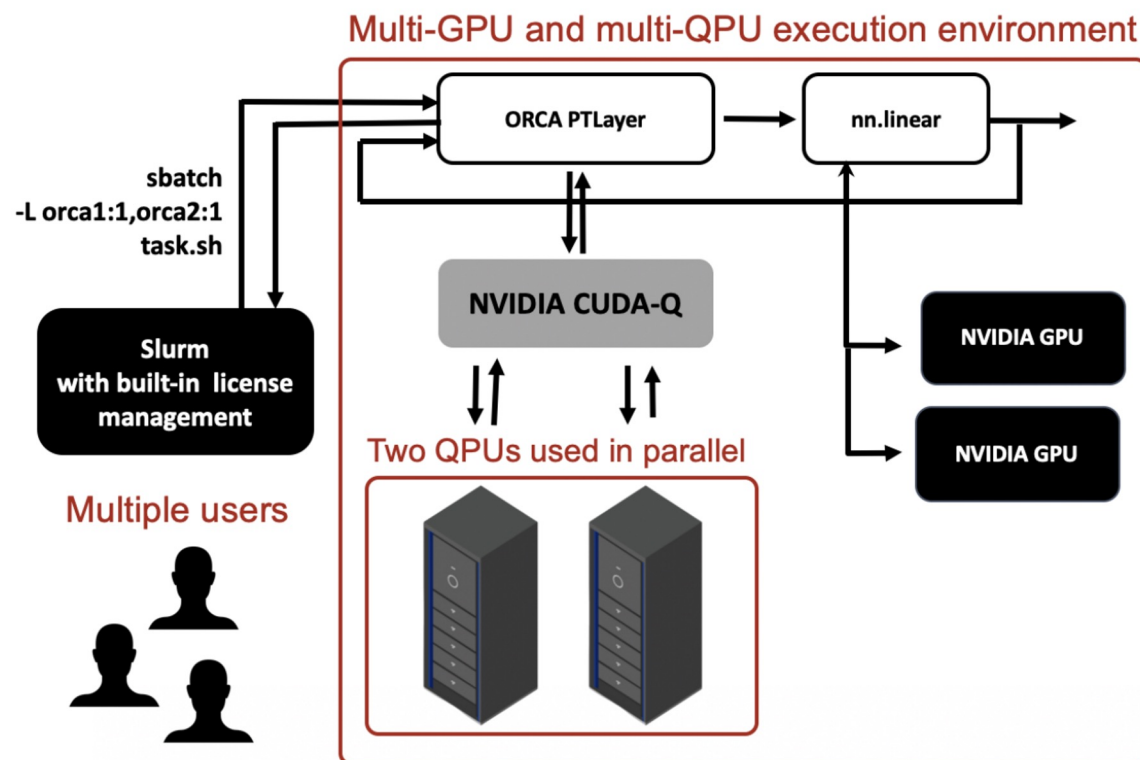

# Users

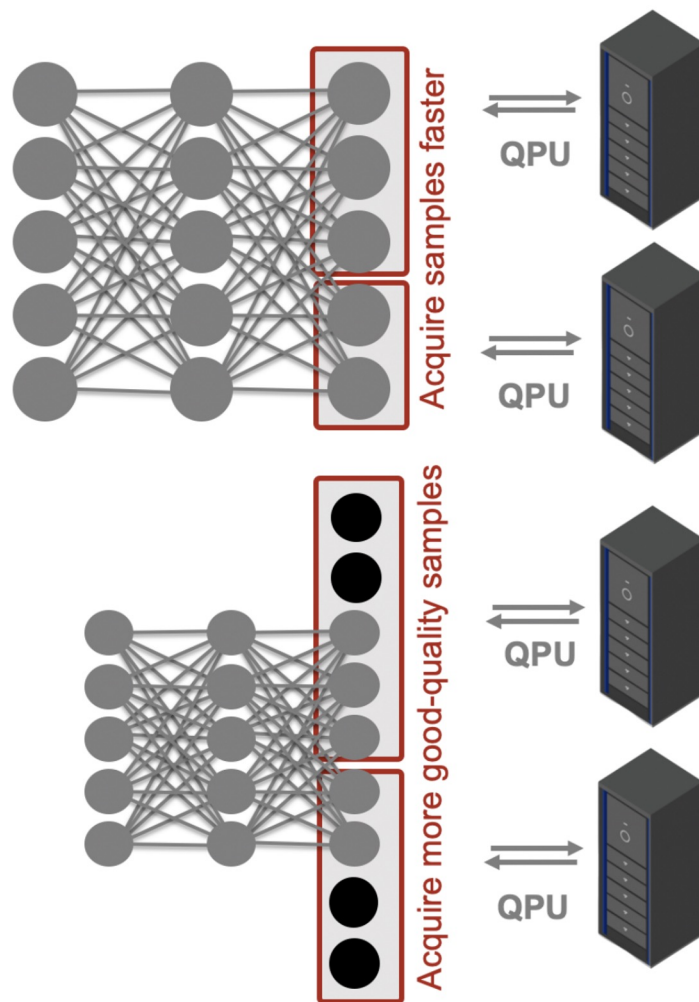

**Test 1**

**Test 2**



# HPC-QC scenario 3

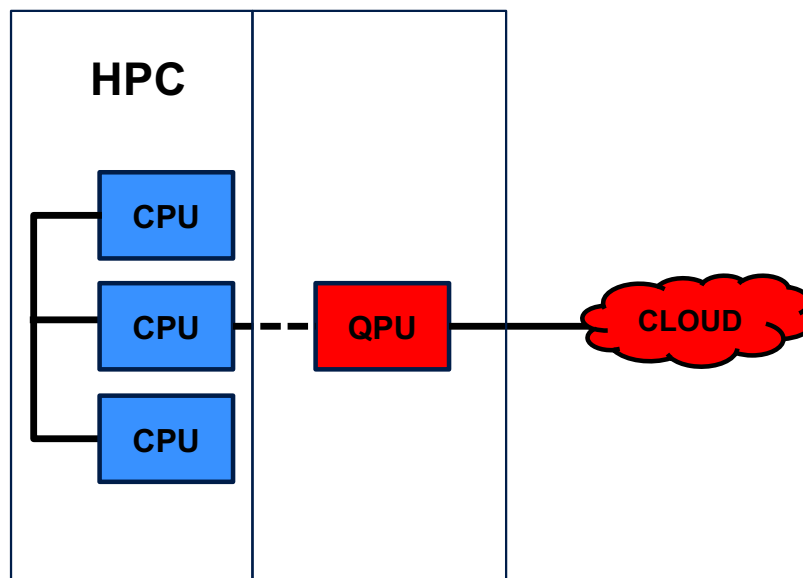

## Local HPC-QC in Poznan

# Users (Students) of QUANTUM ACADEMY

### Algorytm Grovera

- 1. Stan początkowy
- 2. Pierwszy krok algorytmu Grovera: wyrocznia
- 3. Drugi krok algorytmu Grovera: dyfuzja

5. ROZWIĄZANIE PRZYKŁADOWEGO PROBLEMU Z UŻYCIEM BIBLIOTEKI QISKIT

- 1. Rozwiązanie przykładowego problemu z użyciem biblioteki Qiskit

6. PODSUMOWANIE

- 1. Podsumowanie kursu

7. SPRAWDŹ SWOJĄ WIEDZĘ

- 1. Instrukcja
- 2. Quiz

Jeśli oba kubity mają taką samą wartość, pomocniczy kubit przyjmie wartość 0. Poniżej znajduje się schemat obwodu dla pierwszego samolotu:

Poprzednia lekcja 1. Stan początkowy

Następna lekcja 3. Drugi krok algorytmu Grovera: dyfuzja

### Symulatory komputerów kwantowych

- 1. Stany czyste i stany mieszane
- 2. Definicja macierzy gęstości
- 3. Złożoność macierzy gęstości
- 4. Symulator macierzy gęstości w Qiskit Aer

4. PODSUMOWANIE

- 1. Podsumowanie kursu
- 2. Notebook: przykłady z kursu

5. SŁOWNICZEK

- 1. Podstawowe pojęcia

6. SPRAWDŹ SWOJĄ WIEDZĘ

- 1. Instrukcja
- 2. Quiz

### 2. Notebook: przykłady z kursu

A teraz jeśli chcesz, możesz uruchomić całość przedstawionego w kursie kodu w zintegrowanym środowisku pythonowym.

```
[ ]: from qiskit import QuantumCircuit
from qiskit_aer import AerSimulator

# Generacja 3-kubitowego stanu GHZ
circ = QuantumCircuit(3)
circ.h(0)
circ.cx(0, 1)
circ.cx(1, 2)
circ.measure_all()

# Tworzenie symulatora wektora stanu
simulator = AerSimulator(method='statevector')
# Uruchamianie obliczeń
```

Poprzednia lekcja 1. Podsumowanie kursu

Następna lekcja 1. Podstawowe pojęcia

Over 45 online open educational courses of different levels (A1-C2) with almost 60% coverage of topics from **European Quantum Competence Framework for Quantum Technologies**



# HPC-QC scenario 3.1

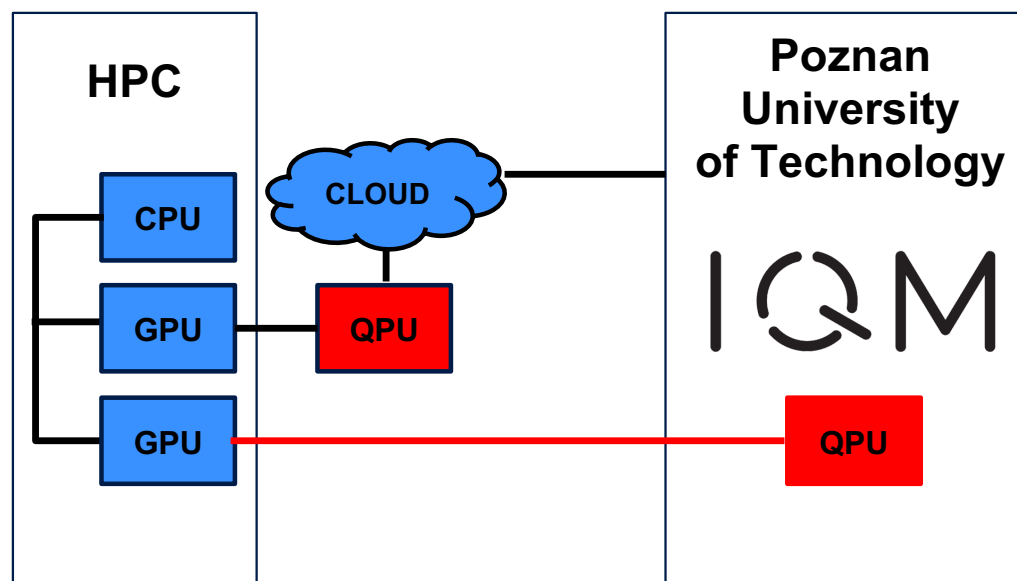

## Local HPC-QC in Poznan

# QUANTUM API

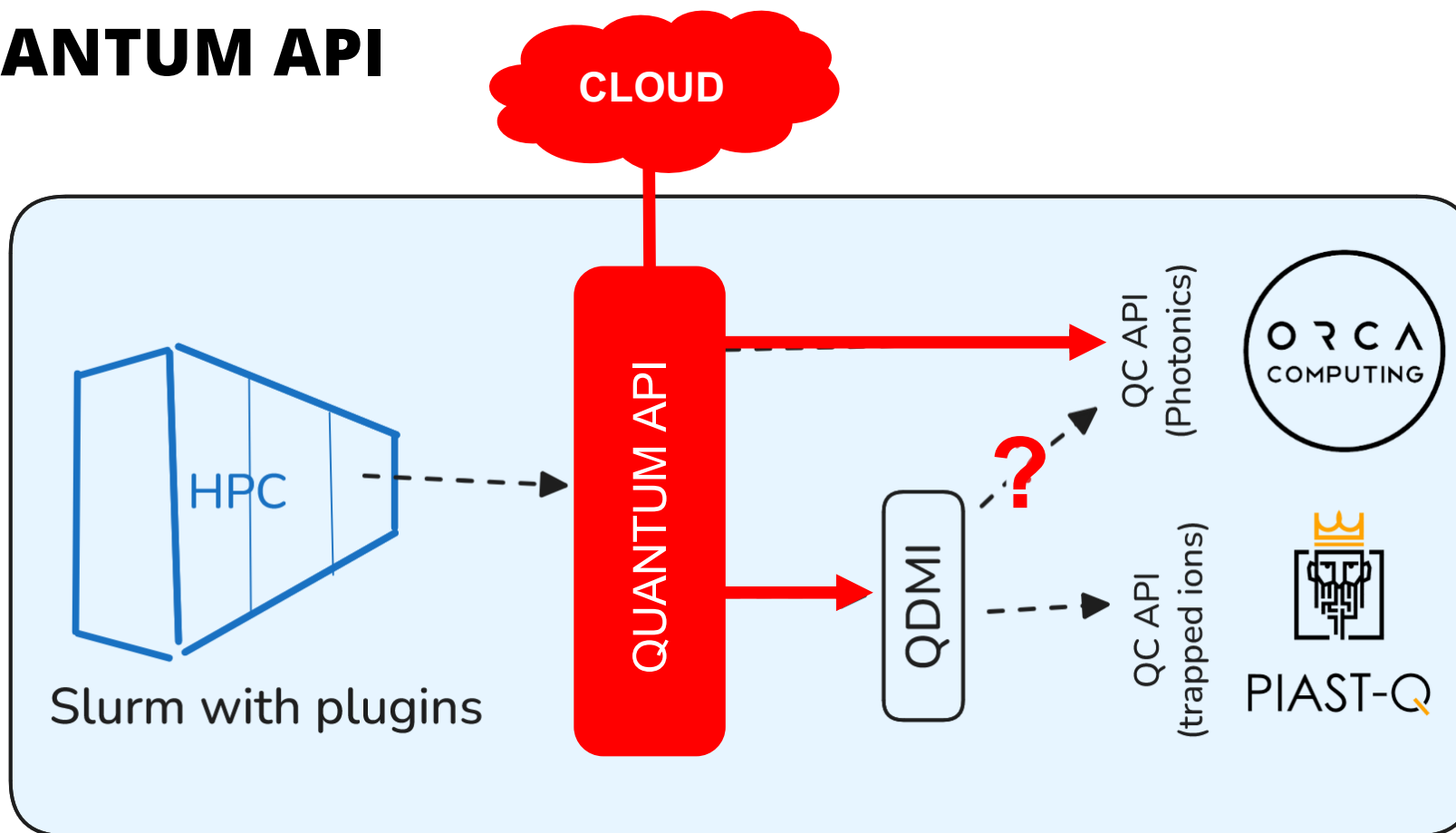

# QUANTUM API

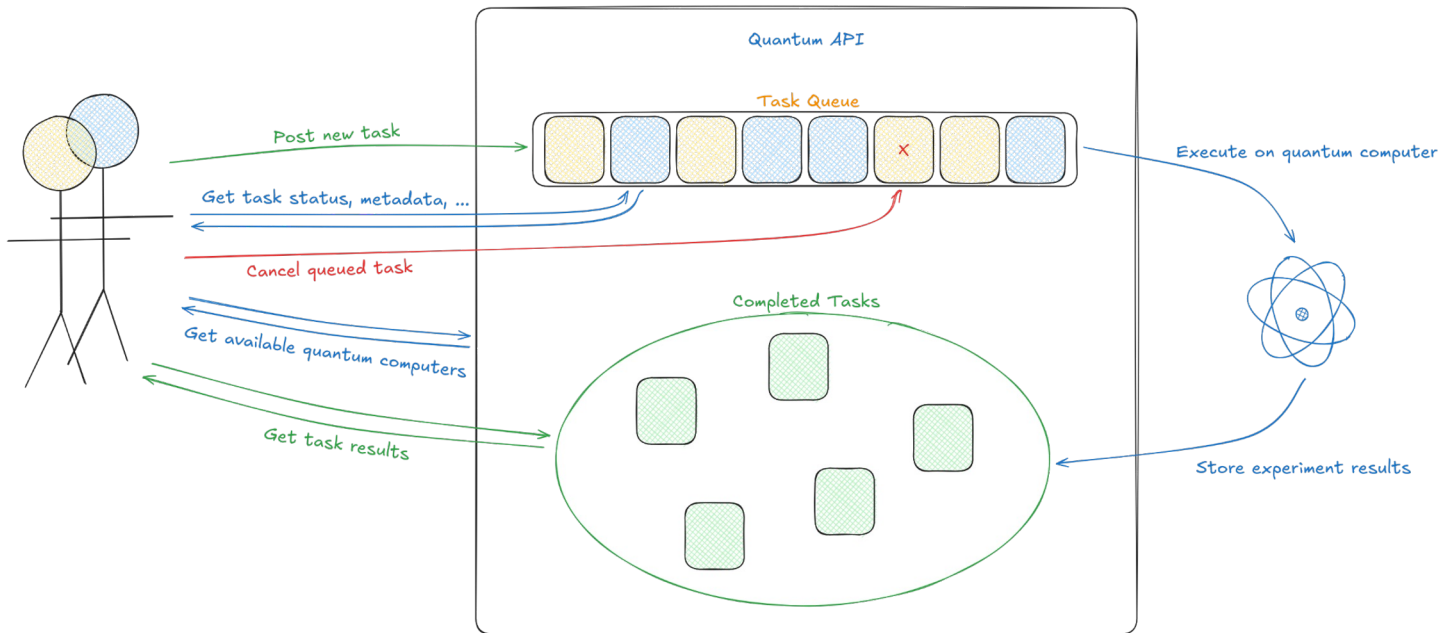

## Health

GET /api/health/test-connection Test Connection

## Tasks

GET /api/client/tasks/{task\_uid}/status Check Task Status

GET /api/client/tasks List Tasks

POST /api/client/tasks Create Task

GET /api/client/tasks/{task\_uid} Get Task

POST /api/client/tasks/{task\_uid}/cancel Cancel Task

GET /api/client/tasks/{task\_uid}/meta Meta

GET /api/client/tasks/{task\_uid}/results Results

## Machines

GET /api/client/machines/{machine}/jobs/{job\_id}/status Status

GET /api/client/machines Get Quantum Machines Names

GET /api/client/machines/queue-count Get Queue Counts



# Where are we now?

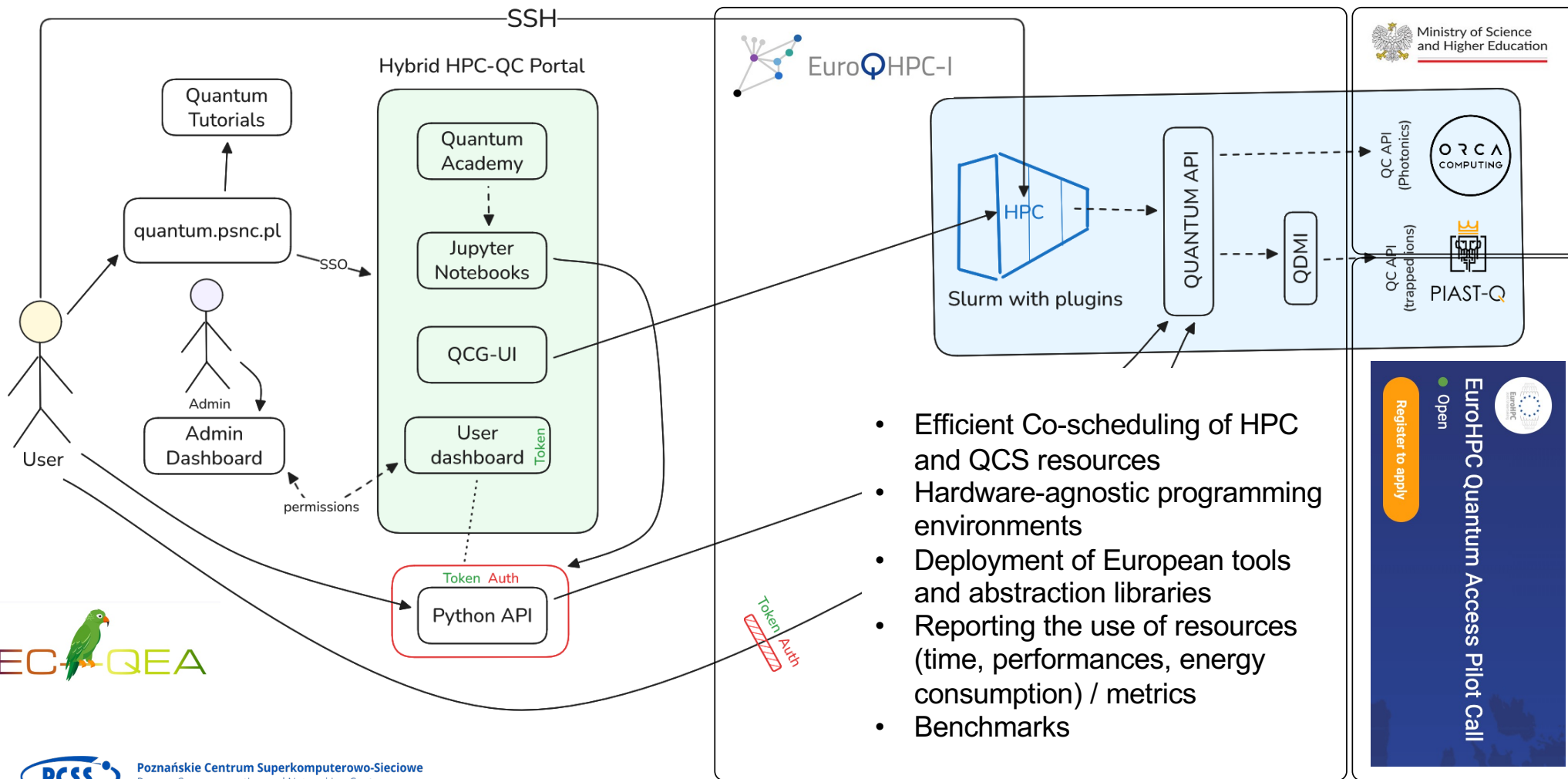

- Efficient Co-scheduling of HPC and QCS resources
- Hardware-agnostic programming environments
- Deployment of European tools and abstraction libraries
- Reporting the use of resources (time, performances, energy consumption) / metrics
- Benchmarks



# HPC-QC integration

Cloud-based

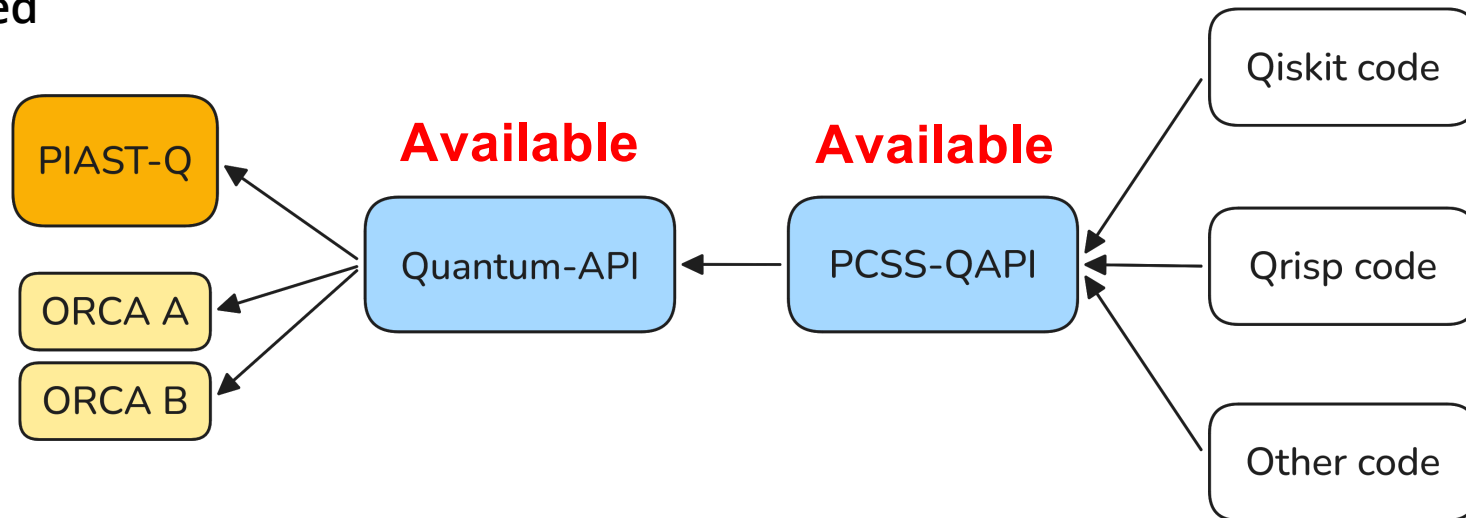

The PIAST-Q (trapped-ion) and two ORCA (photonic) are accessible via the REST API offering full compatibility with Qiskit, Qrisp, and other code. Using secure access tokens, users can submit workloads directly from their local laptops.

Python interface for interacting with the `pcss-qapi` for accessing quantum computing resources at PCSS

# HPC-QC integration



Direct Slurm access

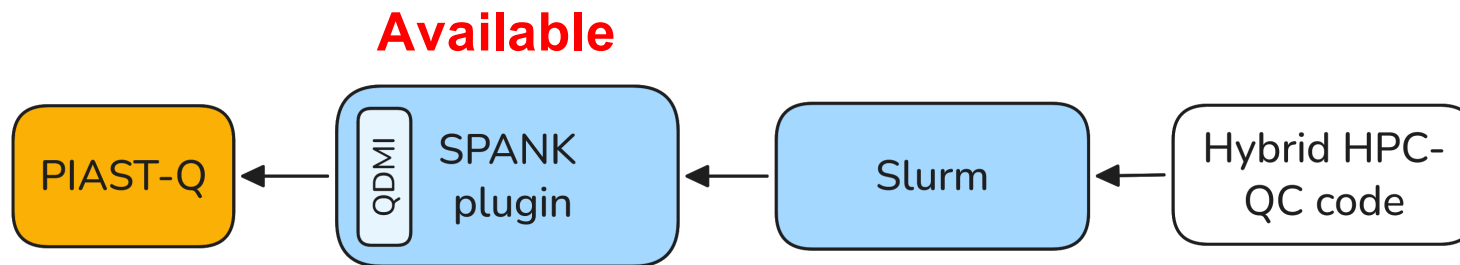

Source and doc:

<https://gitlab.pcss.pl/quantum/psnc-sdk/slurm-hpc-plugin/-/tree/main/doc>

# HPC-QC integration

qbatch

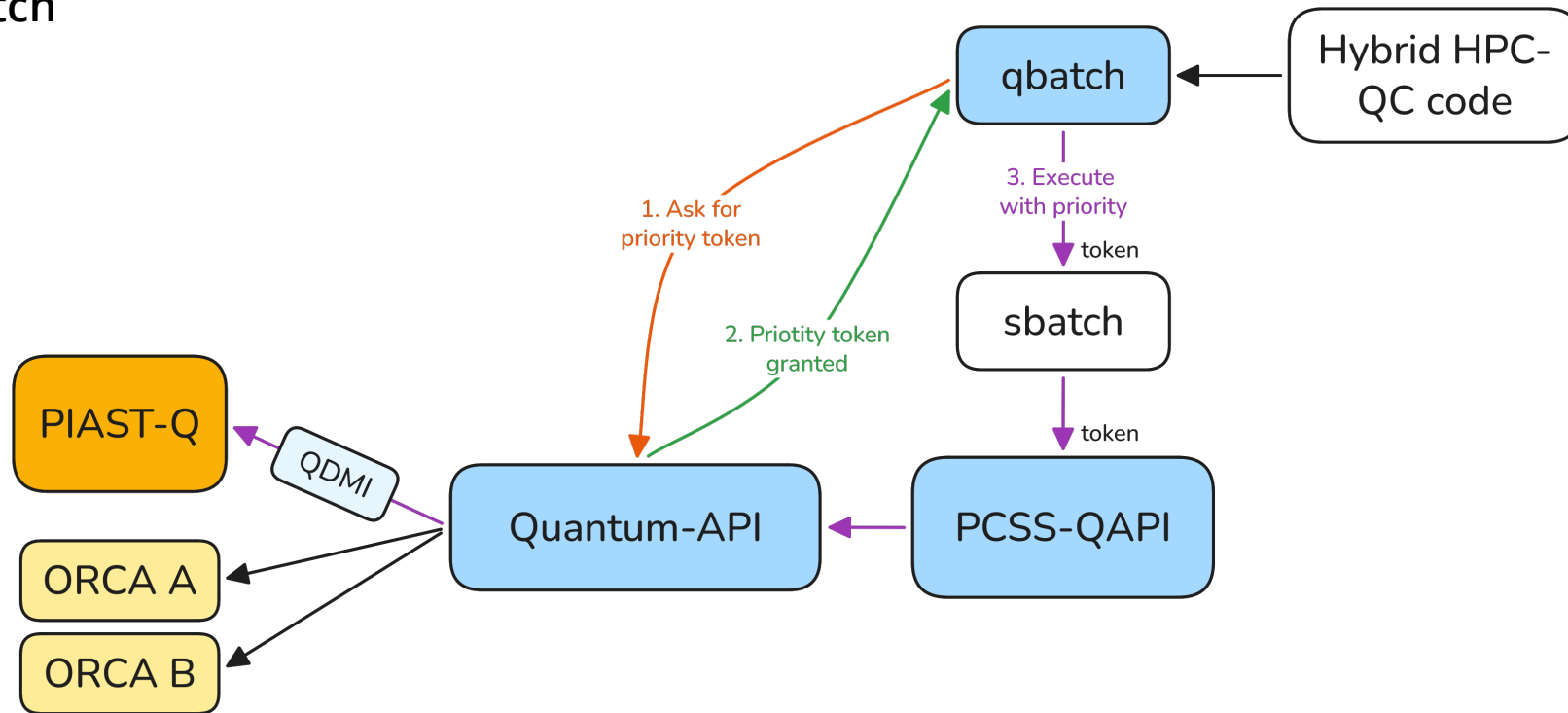

# HPC-QC integration

qbatch as a SPANK plugin in Slurm

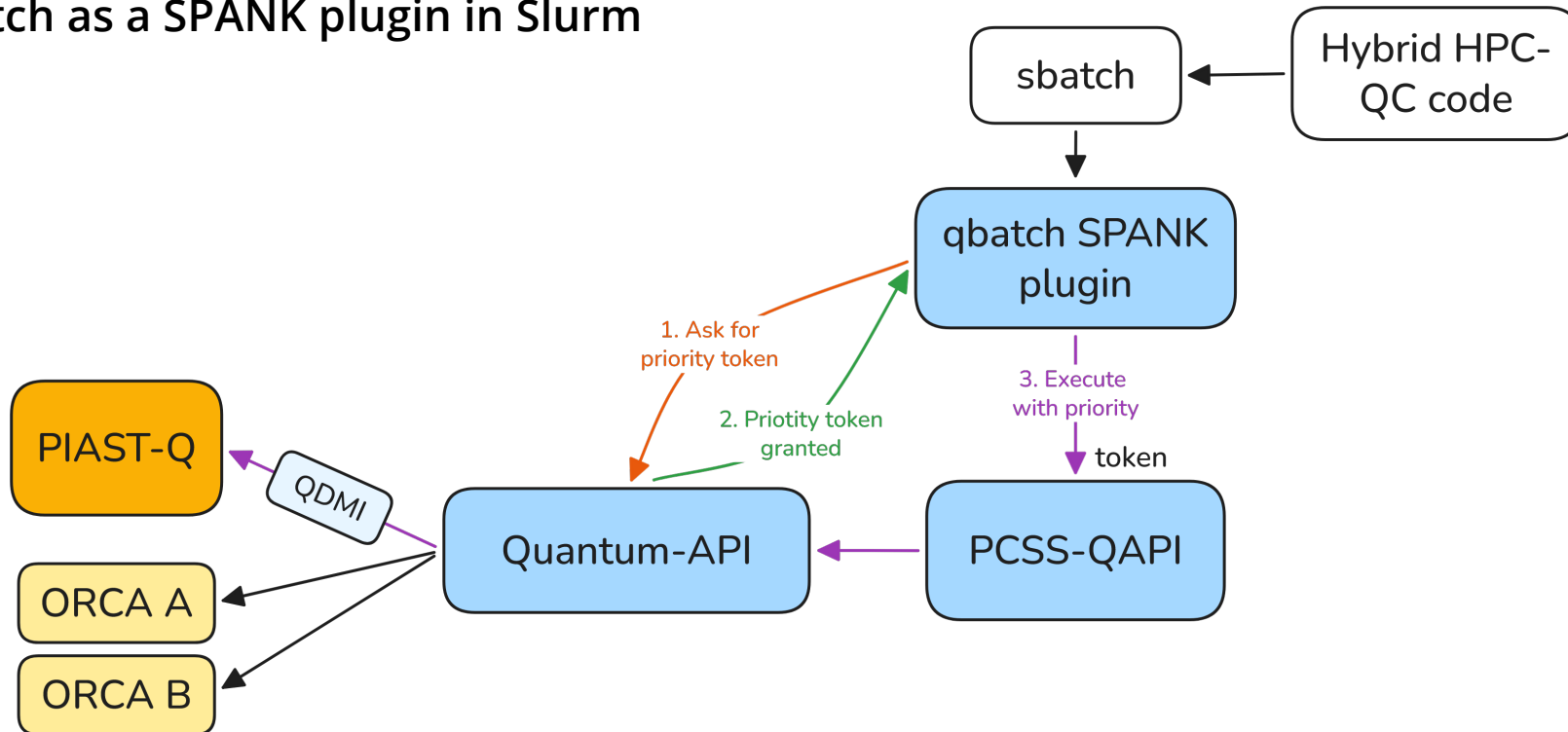

# HPC-QC scenario 4

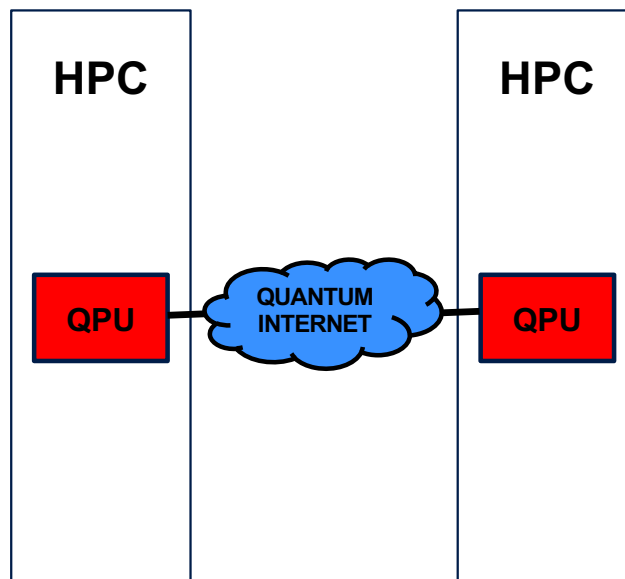

## Distributed HPC-QC in Poland



# HPC-QC & Quantum Internet

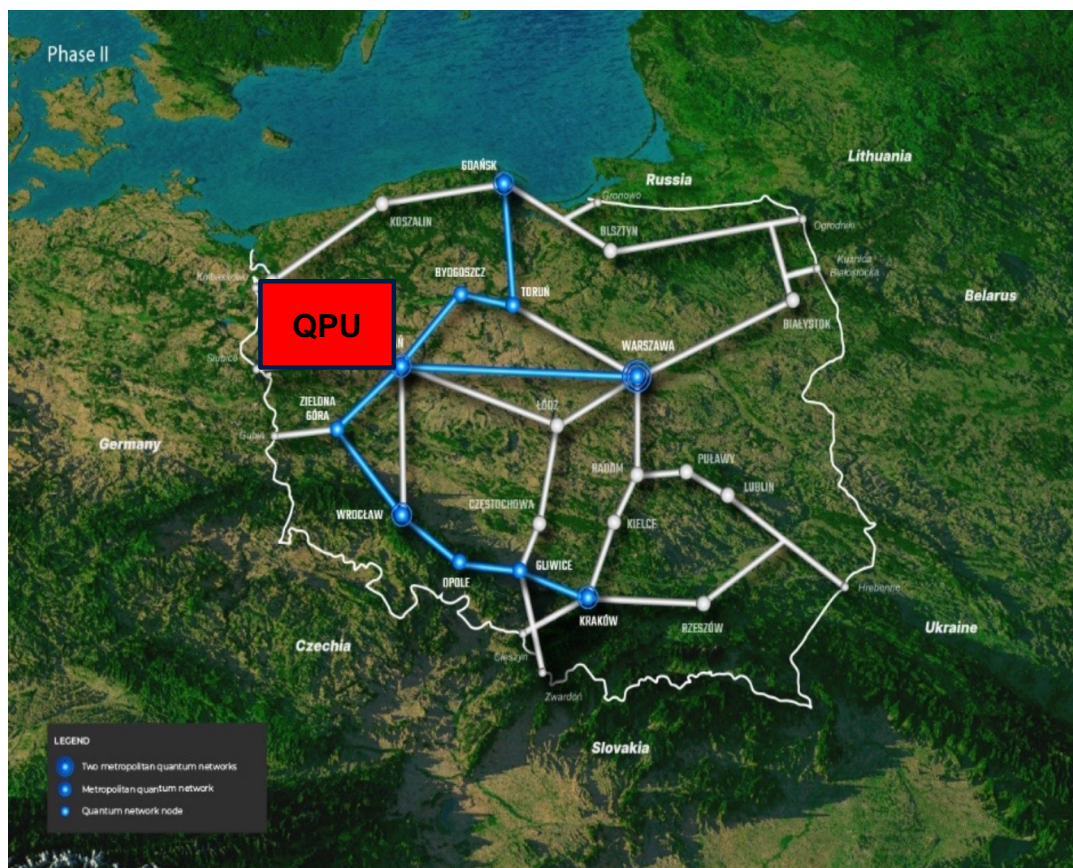

## PIONIER-Q NREN

- 1770 km of QKD links implemented in March 2024 among all the HPC centers in Poland
- Dedicated fibers and KMS network
- Intermediary nodes in main cities of Poland and ready to QKD metro system installations
- Each partner has 2 QKD metro systems with encryptors
- Additional MAN networks connected
- QKD and quantum communication protocols can be implemented and simulated on quantum computing infrastructure

# HPC-QC & Quantum Internet

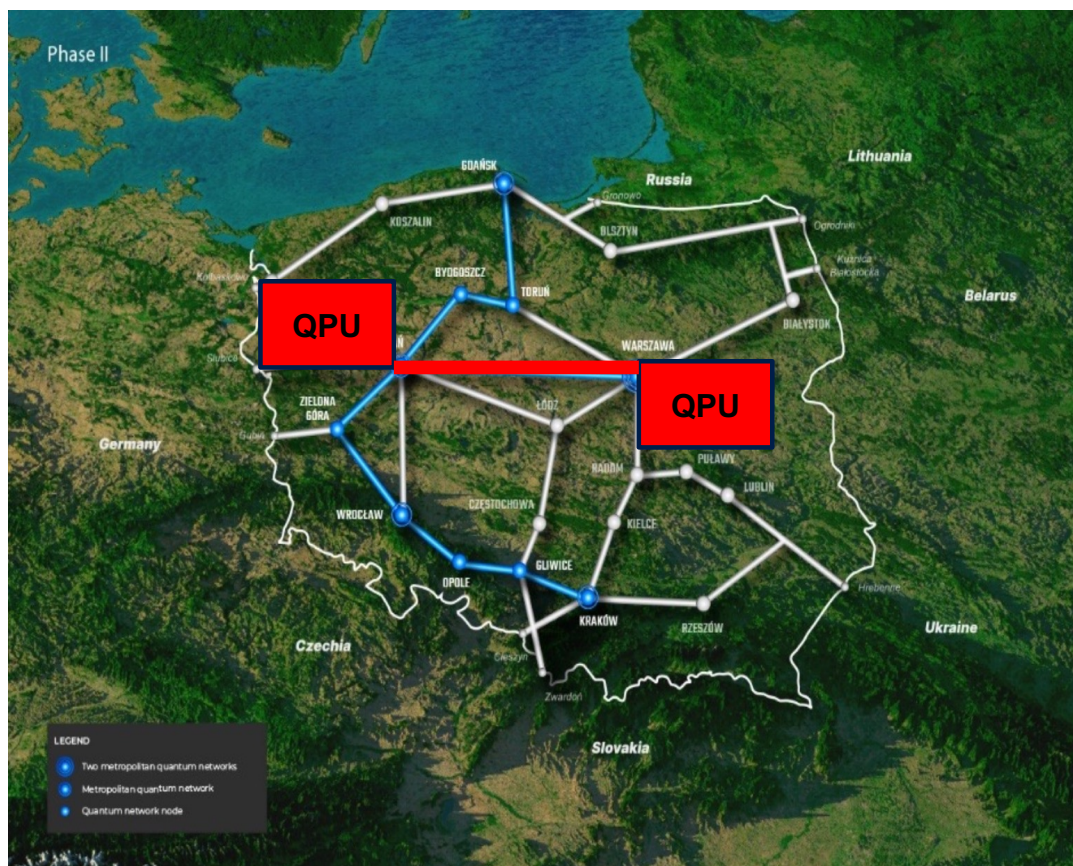

## PIONIER-Q NREN

- 1770 km of QKD links implemented in March 2024 among all the HPC centers in Poland
- Dedicated fibers and KMS network
- Intermediary nodes in main cities of Poland and ready to QKD metro system installations
- Each partner has 2 QKD metro systems with encryptors
- Additional MAN networks connected
- QKD and quantum communication protocols can be implemented and simulated on quantum computing infrastructure
- Testbed preparations for distributed Quantum Computing and Quantum Internet scenarios

# HPC-QC & Quantum Internet

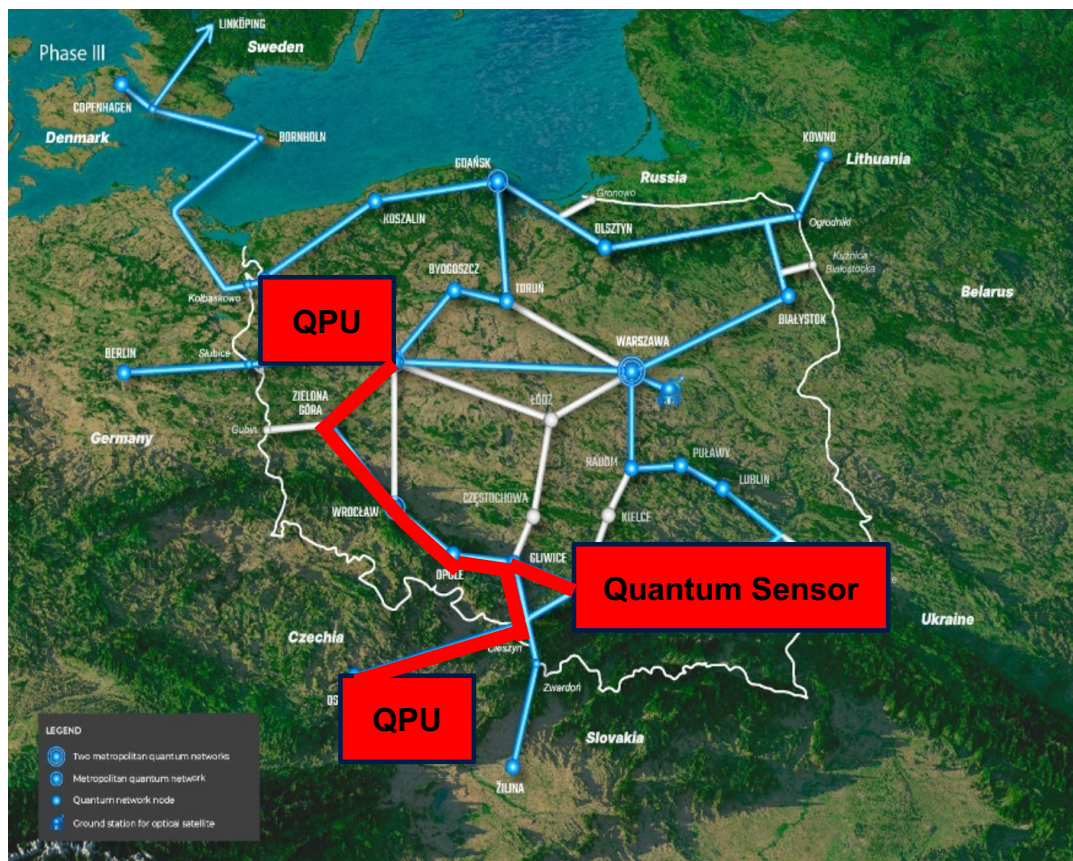

EuroQCI CEF Call proposals – GAP Phase

- **Direct cross-border connections with Denmark, Germany, Czech Republic, Slovakia, Lithuania**
- 2 OGS satellite projects, 1 national and 1 with cooperation with Czech Republic and Slovakia
- Prepared in March 2025

HPC-QC used also for

- **Quantum communication** – QKD network optimization, monitoring data analysis, digital twin, simulation
- **Quantum sensing** – sensors measurement data analysis and processing

# Summary

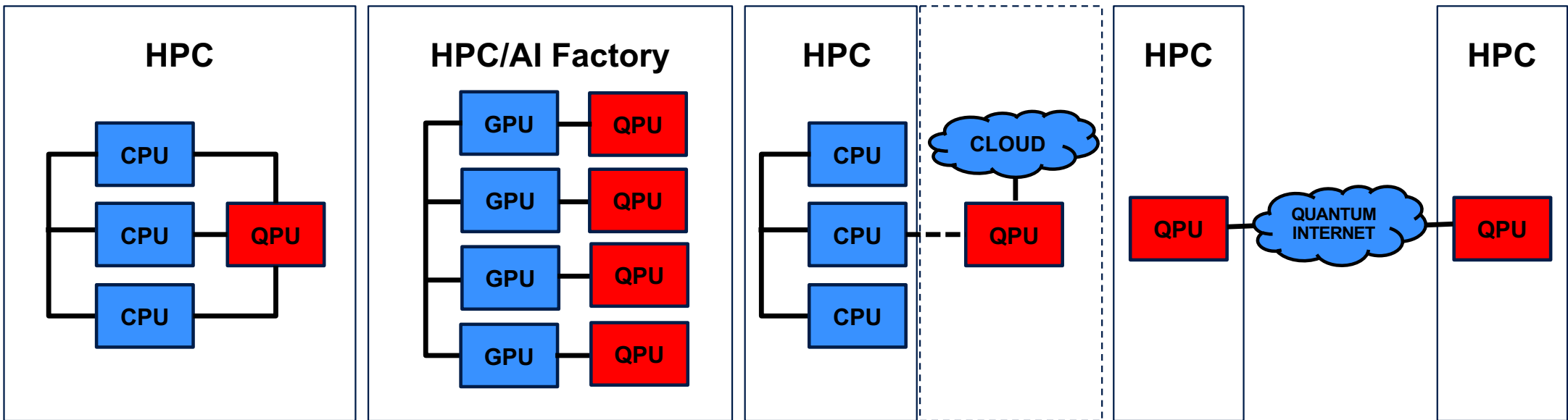

**Which HPC-QC integration option are you going for?**

**Thank You!**



Poznańskie Centrum Superkomputerowo-Sieciowe  
afiliowane przy Instytucie Chemii Bioorganicznej PAN